

# MANUAL ADJUSTABLE ERGONOMIC WORK BENCH- EWB-7236

APPROX WEIGHT: 339 lbs.  
DOES NOT INCLUDE WEIGHT OF POWER OR PACKAGING!!!

\*\*\* ANY ADDITIONS, DELETIONS, OR OMISSIONS MUST BE CORRECTED ON THIS DRAWING AS THIS DRAWING WILL BE CONSIDERED ALL INCLUSIVE \*\*\*

ALL GRAPHICS PROVIDED ARE FOR REFERENCE ONLY. IF CERTAIN DIMENSIONS ARE CRITICAL PLEASE VERIFY THOSE DIMENSIONS WITH YOUR SALESPERSON

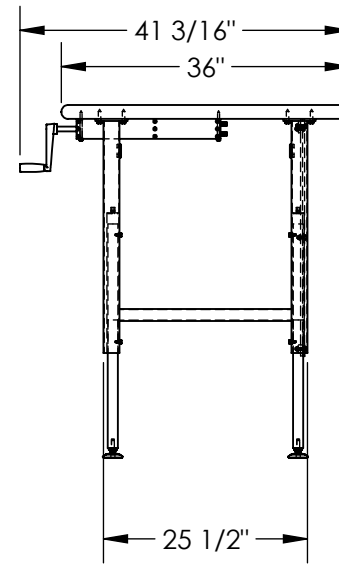
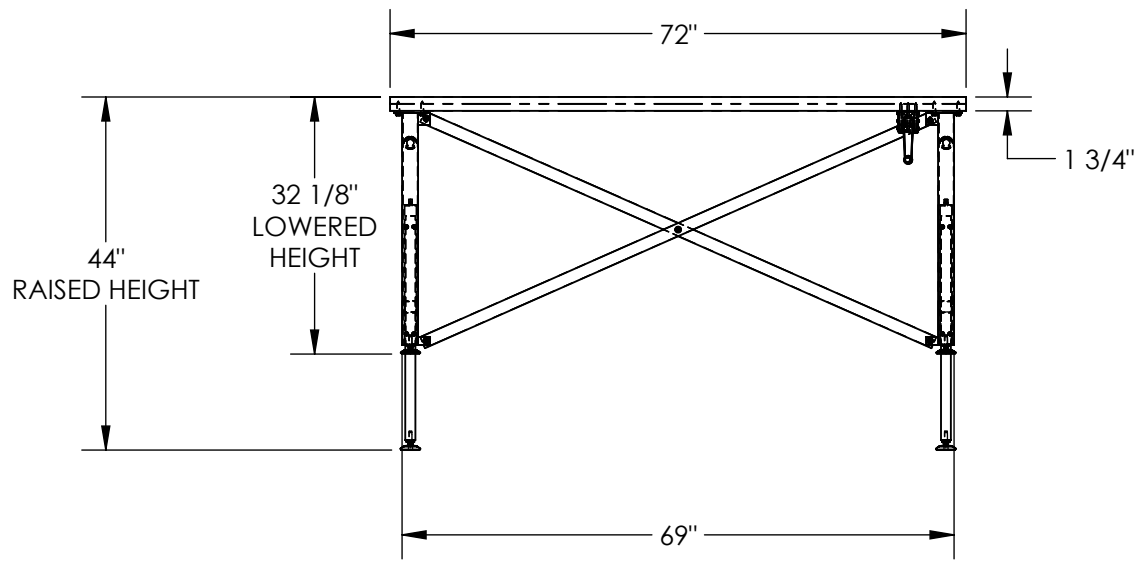

## STANDARD FEATURES

- MODEL NUMBER IS EWB-7236
- OVERALL WIDTH IS 41 3/16"
- USABLE WIDTH IS 36"
- OVERALL LENGTH IS 72"
- USABLE LENGTH IS 72"
- MAX RAISED HEIGHT IS 44"
- MAX LOWERED HEIGHT IS 32 1/8"
- MAX UNIFORM CAPACITY IS 750 LBS
- FOLD AWAY CRANK HANDLE FOR MANUAL OPERATION
- HYDRAULIC SYSTEM RAISES PLATFORM EVENLY
- PLATFORM IS A MAPLE BENCH TOP W/ CATALYZED LACQUER FINISH
- 180° BULL NOSE ON 72" SIDE OF PLATFORM
- LEGS ARE TOUGH BAKED IN POWDER COATED BLUE FINISH

## SPECIAL FEATURES

NONE

DIMENSION TOLERANCE ± 1/4"

<b>A P P R O V A L</b>	I, THE UNDERSIGNED, AGREE THAT THE PRODUCT AS REPRESENTED SATISFIES DESIGN AND DIMENSION REQUIREMENTS. I ALSO ACKNOWLEDGE MY DUTY TO CONFIRM PRODUCT AND INSTALLATION COMPLIANCE WITH ALL APPLICABLE FEDERAL, STATE AND LOCAL REGULATIONS AND STANDARDS.	
	<b>ANY MODIFIED UNITS ARE NON-RETURNABLE</b>	
	[ ] As drawn      [ ] As marked	
	Signed: _____ Date: _____	
Printed Name: _____		
<i>LEAD TIME WILL START UPON RECEIPT OF SIGNED APPROVAL DRAWING</i>		

FOR INTERNAL USE ONLY  
PROJECT SIGN OFF

SALES	
ENG.	
FAB.	
POWER	

DISTRIBUTOR'S NAME:		P.O.#
VESTIL MANUFACTURING		X
DRAWN BY: DEY		W.O.#
DATE: 9/5/12		X
REFERENCE: X	SCALE: 1:24	SALES: X
QUOTED LEAD TIME: X	QUOTE # X	FILE NAME:
		43-007-002